



Programmes/functions

- Microwave
- Quartz grill
- Microwave/grill combination
- 10 automatic programmes

Special features

- 2 recipe memory positions
- InnoWave technology for more even cooking results
- Electronic control

Features

- Silver display EasyClock
- Automatic off programmer
- Interior light
- Stainless steel interior
- Microwave stirrer
- 5 power level microwave
90-180-360-600-900 Watts
- Right hinged side opening door

Design

- Bevelled glass fascia
- Symmetrical design
- Central oval bevelled control
- Retractable control

Standard accessories

- 1 wire stand
- 1 full width glass tray

Optional accessories

- 1/3 GN Ceramic dish, 38mm deep Z1665X0
- Frameless installation recommended for wall units, but also suitable for tall housing

Series 3 C54R70N3GB Microwave oven and grill Stainless steel

Microwave
in a wall-hanging cupboard

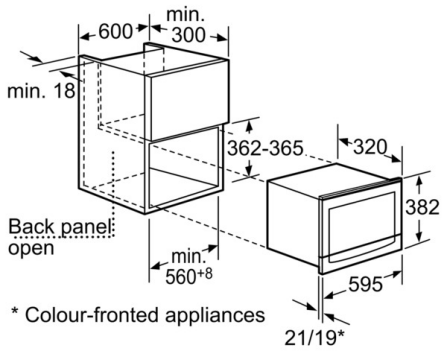

Measurements in mm

Microwave
front panel overhang

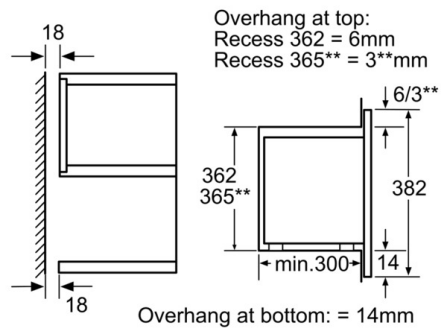

Measurements in mm

Microwave
in a tall cupboard

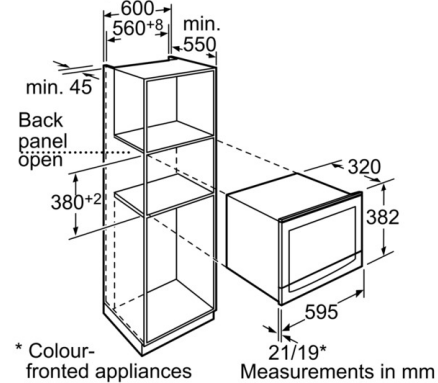

Measurements in mm

Characteristics

Type of micro-wave oven : MW+Grill
function

Type of control : Electronic

Color / Material Front : Stainless steel

Dimensions of the product (mm) : 382 x
595 x 320

Cavity dimensions (mm) : 220 x 350 x 270

Length of electrical supply cord (cm) : 150

Net weight (kg) : 17.0

Gross weight (kg) : 20.0

Consumption and connection features

Maximum micro-wave power (W) : 900

Connection rating (W) : 1990

Current (A) : 10

Voltage (V) : 230

Frequency (Hz) : 50

Plug type : GB plug

2015-03-27

Alternative colors available

C54R70N3GB:Stainless steel

Included accessories

1 x glass pan

1 x grid

EAN code

4242004159759

Series 3 Technical Data 1

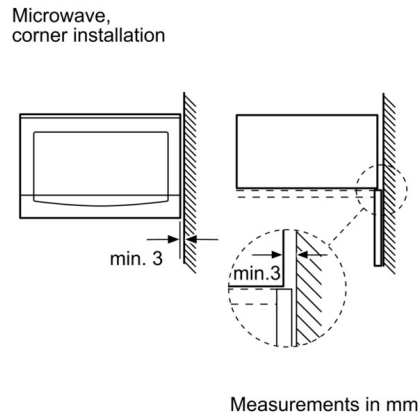
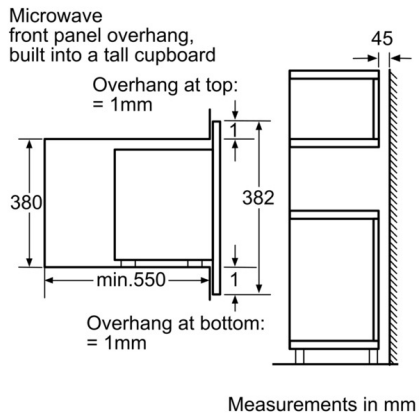

Series 3

Technical Data 2