



Special features

- CircoTherm® eco
- Retractable soft eject control
- Water tank empty indicator
- Water tank capacity 0.5 litre
- De-scaling programme
- NeffLight (2 x 20 Watt halogen lamps)
- SoftClose Slide&Hide door
- Bevelled design Revolution handle
- Telescopic FlexiRail® system with stop function (1 pair)
- Telescopic rails (1 pair)
- Electronic control
- Silver ClearText display
- Illuminated function display
- Silver Temperature display
- Heating up indicator
- Residual heat indicator
- Temperature proposal
- Safety switch off

Features

- Permanent control panel lock
- Control panel lock
- Silver display EasyClock
- Automatic on/off programmer
- 1 x 40 Watt lamp
- QuickConnect shelf supports
- 4 shelf positions
- Full glass inner door
- Triple glazed door
- Heat reflective glass
- TitanEnamel
- CeramiClean® (back, roof and side liners)
- Electronic oven cleaning setting

Design

- Bevelled glass fascia
- Bevelled oval controls
- Symmetrical design
- Central oval bevelled control
- Retractable controls
- 'U-form' door design
- Bevelled bar handle
- Fixed bevelled oval controls
- Stainless steel edged door design
- Straight bar handle

Performance/technical information

- 67 litre capacity
- Energy efficiency rating A-30%
- Total connected load 3.68KW

Standard accessories

- 1 pair of telescopic rails
- 1 full width enamel tray
- 1 high/low wire shelf

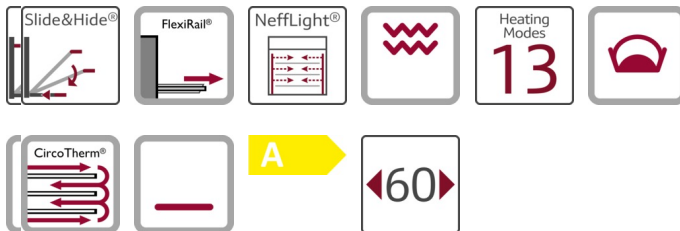

AquaAssist Series 5 B46C74N3GB Single oven

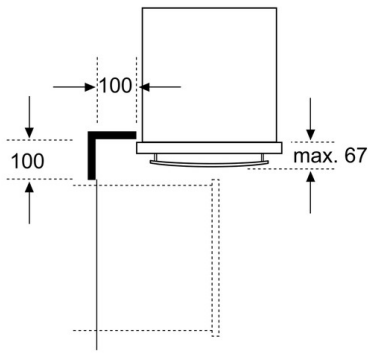

Measurements in mm

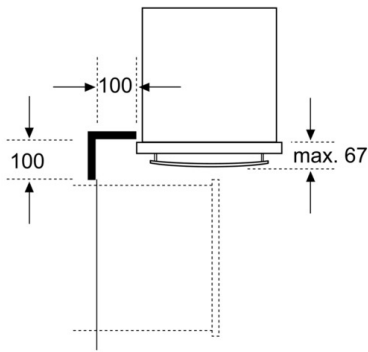

Measurements in mm

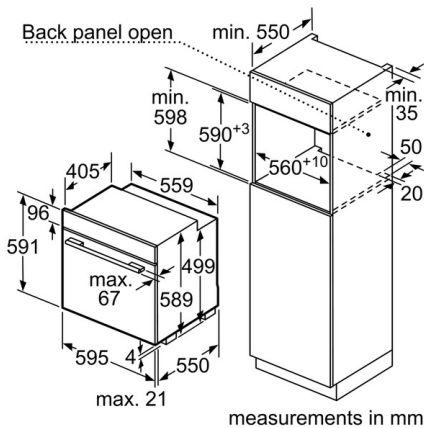

measurements in mm

Characteristics

Color / Material Front : Stainless steel
 Construction type : Built-in
 Integrated Cleaning system : Catalytic all sides
 Required niche size for installation (HxWxD) : 590-593 x 560-570 x 550
 Dimensions of the product (mm) : 595 x 595 x 550
 Control Panel Material : stainless steel + glass insert
 Door Material : Glass
 Net weight (kg) : 42.0
 Usable volume of cavity (l) : 67
 Cooking method first cavity : Bottom heat, Bread Baking Setting, Conventional heat, Dough proving setting, Full width grill, Half width grill, Hot Air, Hot Air-Eco, low temperature cooking, Pizza setting, regeneration, steaming level, Thermo grill
 First cavity material : Enamel
 Temperature control - cavity 1 : electronic
 Number of interior lights : 3
 Approval certificates : CE, VDE

Consumption and connection features
 Number of cavities (2010/30/EC) : 1
 Energy efficiency class (2010/30/EC) : A
 Energy consumption per cycle conventional (2010/30/EC) : 0.96
 Energy consumption per cycle forced air convection (2010/30/EC) : 0.72
 Energy efficiency index (2010/30/EC) : 86.7
 Electrical connection rating (W) : 3680
 Current (A) : 16
 Voltage (V) : 240
 Frequency (Hz) : 50
 Plug type : no plug
 2015-03-27

Alternative colors available

B46C74N3GB:Stainless steel

Optional accessories

Z1240X2 ACCESSORIES COOKER/OVEN
 Z1262X0 glasspan
 Z1272X0 ACCESSORIES COOKER/OVEN
 Z1343X0 Accessory
 Z1512X0 Accessory

Included accessories

2 x baking and roasting shelf cranked
 1 x universal pan
 1 x insert grid

EAN code

4242004151470

AquaAssist Technical Data 1

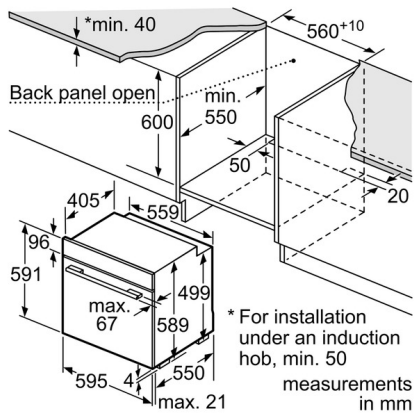

AquaAssist Technical Data 2